

E Band Transmitter, 71-76GHz

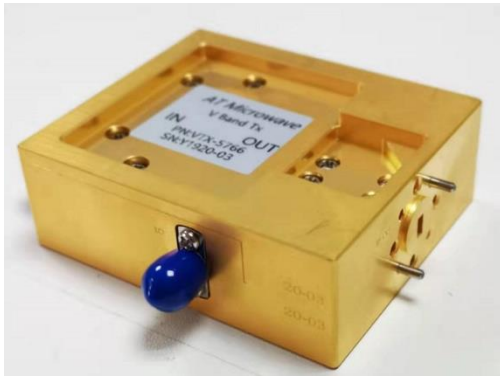

Product Overview

AT-ETX-7176 is a E-Band Transmitter, with gain=12dB, Pout=+20dBm typical.

The Tx is integrated with High Performance GaAs MMIC chips. RF frequency range is 71-76GHz, LO range is 11.8-12.6GHz with x6 times multiplier inside. IF range is DC-10GHz The transmitter is with compact size. LO/IF port is with SMA, and RF port is with standard WR-12.

More information, please visit www.atmicrowave.com

Feature

- ✓ Frequency: 71-76GHz
- ✓ Gain: 12dB typical
- ✓ IF Range: DC-10GHz
- ✓ Pout: +20dBm Typical

Application

- ✓ E Band Communication
- ✓ FOD (Foreigner Objects Debris)
- ✓ Test Equipment
- ✓ ROF (RF Over Fiber)
- ✓ Radar System

Diagram Block

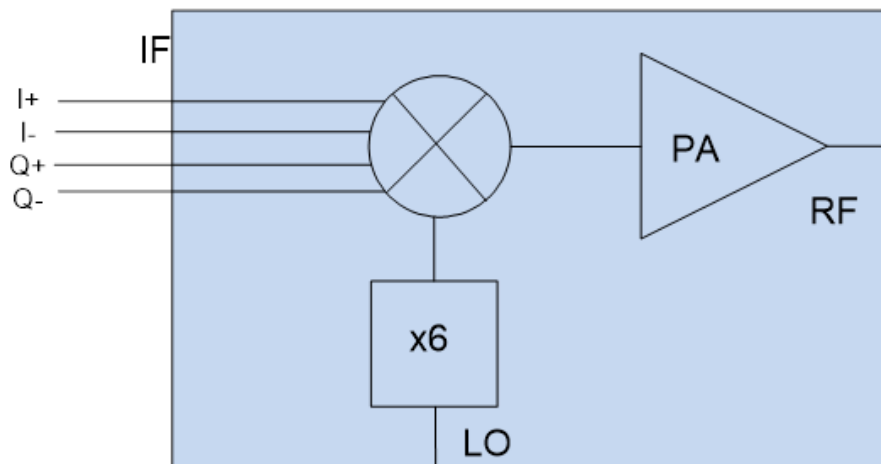



AT-ETX-7176

Compact E Band Transmitter, 71-76GHz

Key Features

Parameter	Min	Typical	Max
RF Frequency		71-76GHz	
IF Frequency (Note1)		DC-10GHz	
LO Frequency	11.3GHz		14.7GHz
Multiplier Factor		X6	
LO Power		+5dBm	+10dBm
P1dB		+18dBm	
Psat		+20dBm	
Conversion Gain(combine IQ)	9	12 dB	
RF Return Loss		-10 dB	
LO Return Loss		-14 dB	
Drain Power Supply		+5/780mA	+8V
RF Port Connector		WR-12	
IF/LO Port Connector		SMA Female	
Weight		310g	
Dimension		50x60x20mm	

Test Condition

Parameter	Setting
IF Input Power	-5dBm
Input Frequency	2GHz
LO Power	+5dBm
Temperature	25C

Absolute Maximum Ratings Table

Parameter	Value
Drain Supply	+9V
If Input Power per/Channel	+7dBm
LO Power	+15dBm
Operating Temperature	0 to +50C
Storage Temperature	-65 to +150C



Test Data:

IF=2GHz, IF Power=-5dBm, combined IQ together.

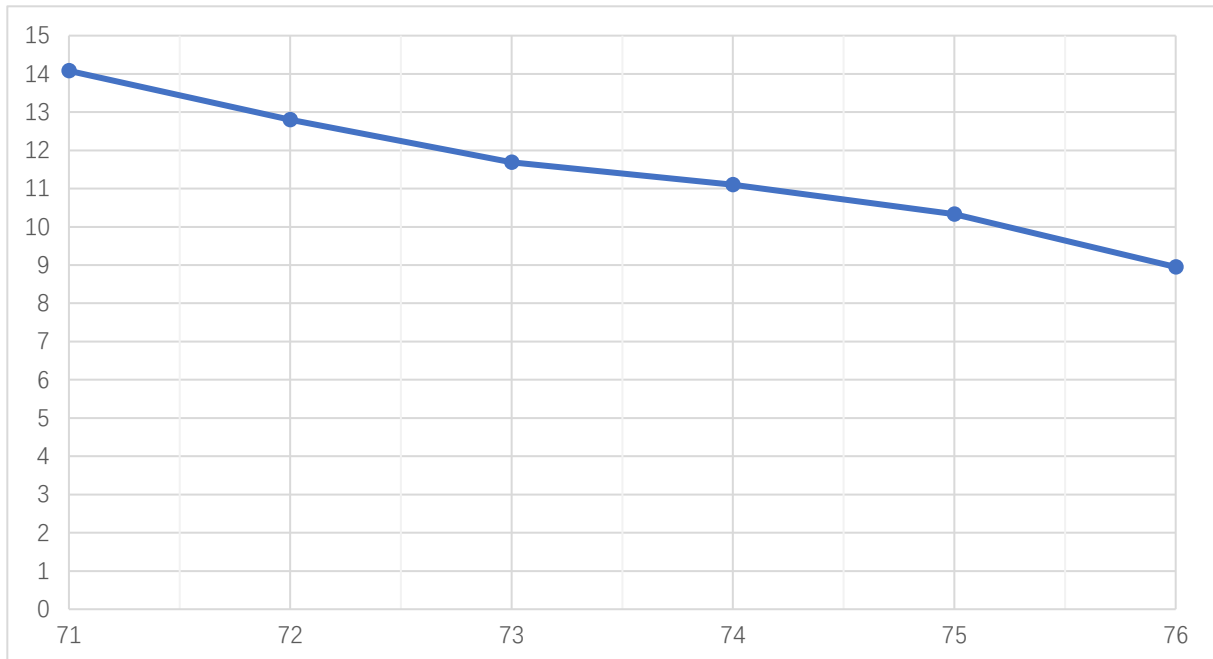

Gain vs Frequency, RF-LO=2GHz,

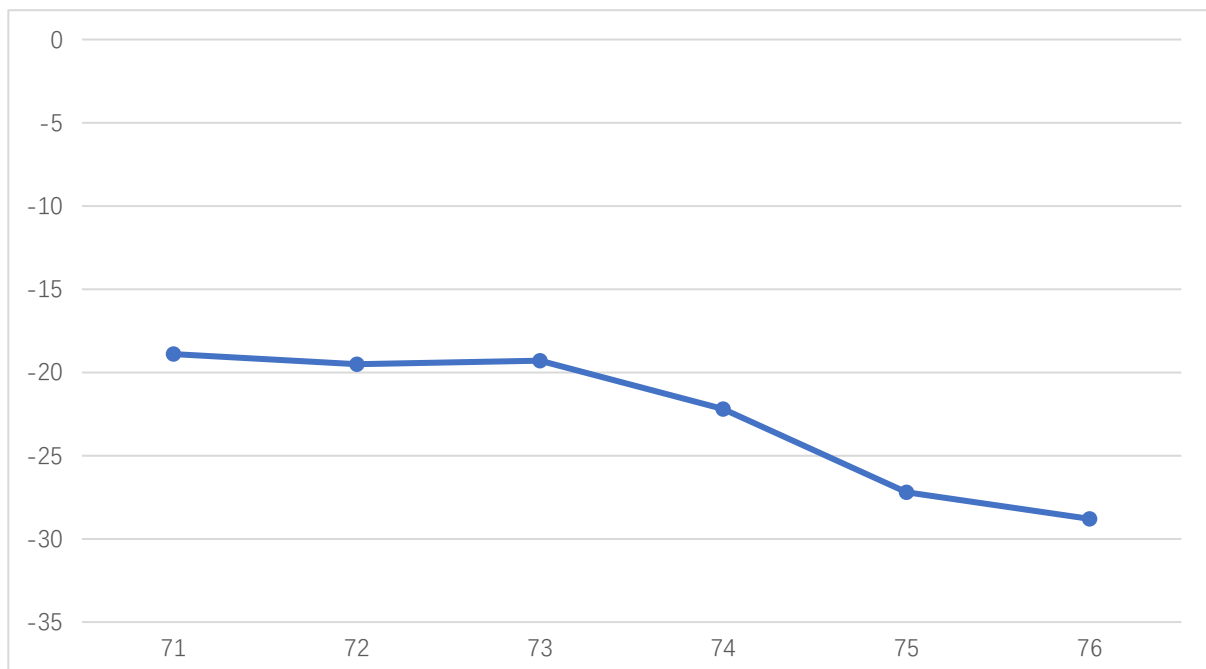

LSB lower band side suppression vs RF Frequency, IF=2GHz



Applicaiton1:

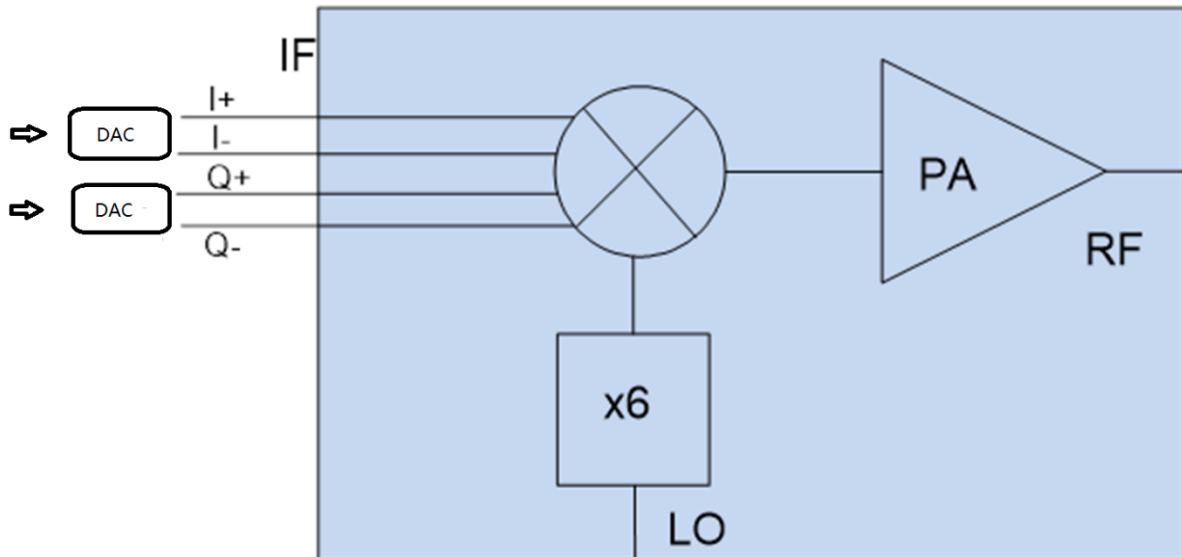

Zero IF Direct Conversion

Applicaiton2:

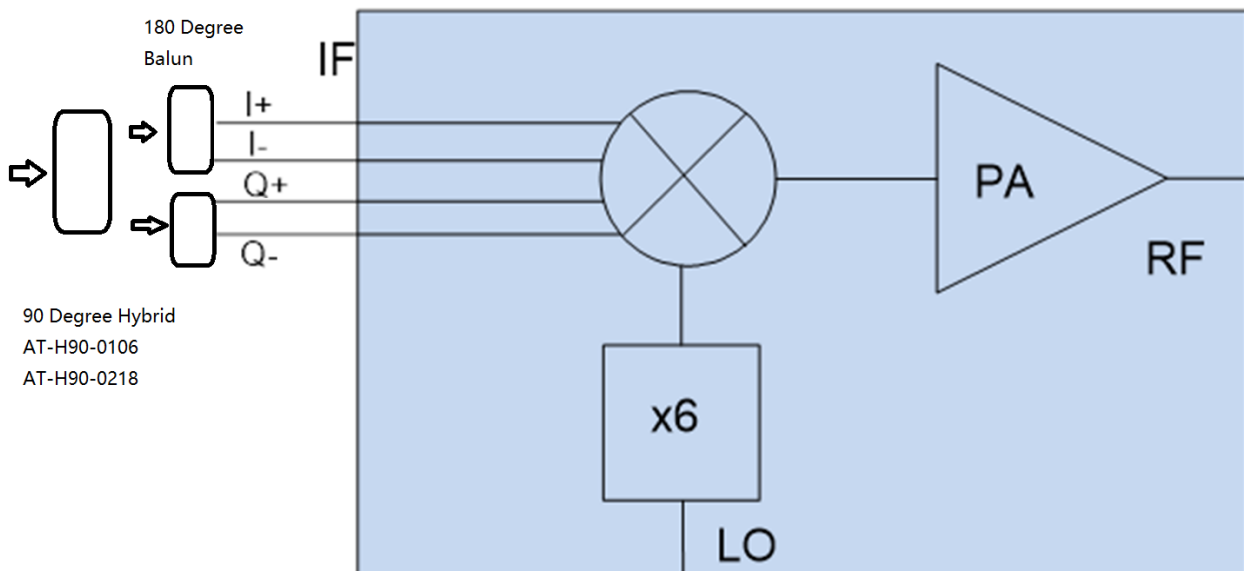

Imaging Rejection Single IF Application

Contact with us for 180degree balun and 90degree hybrid.



Application Note

Mixer is a three port component with RF, LO and IF ports. Normally, a mixer can be used both up and down converter application. Take up converter for example:

General Balance Mixer

For general balance mixer, $RF = LO \pm IF$. There will be both high end $LO+IF$ and Low End $LO-IF$. Take for example, $IF=2GHz$, $LO=80GHz$, so there will be $78GHz$ and $82GHz$ at RF port with same power level.

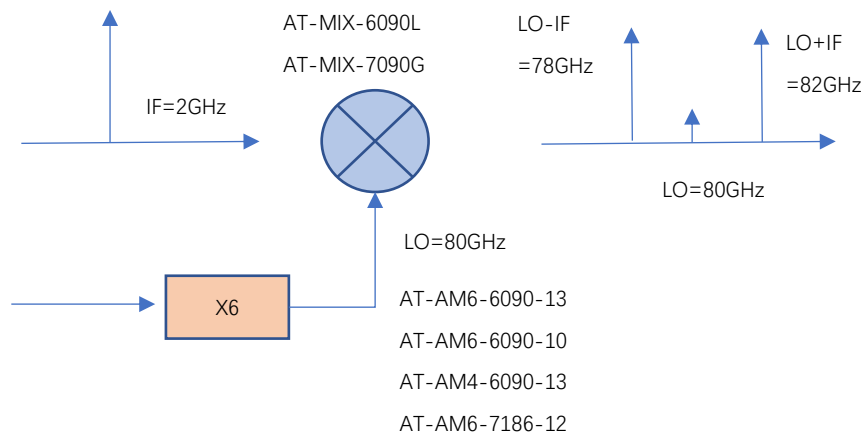

Figure A: General Balance Mixer with Both High and Low Side Output

IQ Mixer used as side suppression Mixer

When $IF=2GHz$, 90 degree hybrid is used at IF port, and IF applies to Input 1 Port of hybrid, you will have high end frequency $RF = LO + IF = 82GHz$, while have side suppression (say $-25dBc$) at Low end frequency $78GHz$.

When you need low end frequency $78GHz$, and make side suppression for high end frequency $82GHz$, just applies IF to Input 2 of the hybrid.

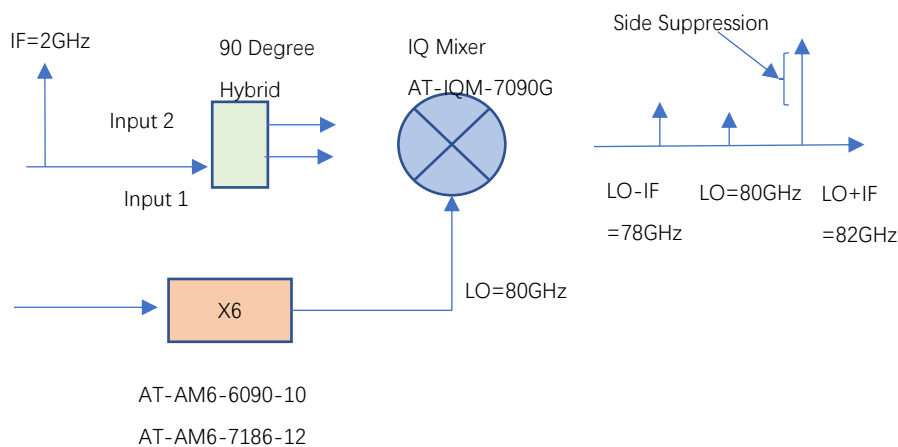

Figure B: IQ Mixer works as side suppression mixer



